

Power-Flo LX[™]

VALUE POOL PUMP SERIES



- Designed for long life with durable corrosion proof materials
- Provides dependable, energy-efficient performance and quiet operation
- Extra-large debris basket keeps pool maintenance to a minimum
- Clear cover lets you see exactly when the basket needs cleaning

Durable, Corrosion-Proof Housing made of high performance PermaGlass XL™ material for years of dependable service and all-weather performance.

Clear cover lets you see when the basket needs cleaning.

Extra large basket extends time between cleaning.

Heavy duty motor offers proven performance and quiet operation.



The industry standard for value and performance

The Hayward Power-Flo LX™ pump series is designed specifically for the rigors of above-ground, on-ground and small in-ground swimming pools. Featuring a heavy-duty motor, PowerFlo LX offers dependable performance and quiet operation. An extra-large debris basket keeps pool maintenance to a minimum, letting you enjoy your pool more. Dependable, quiet and energy efficient, the PowerFlo LX pump series continues to set the standard for value and performance.

PowerFlo LX 220-240V/50Hz/1PH

Model	HP	Service Factor	KW	Pipe Size	Dimension "A"	
					Inches	mm
SP1575LX51	¾	1.0	.56	1½	11⅝"	295
SP158051	1	1.0	.75	1½	12"	305



Super-Size 87-Cubic-Inch (1425cc) Basket

has extra leaf-holding capacity and extends time between cleanings. Rigid construction with load-extender ribbing ensures free-flowing operation for heavy debris loads.

Overall Dimensions

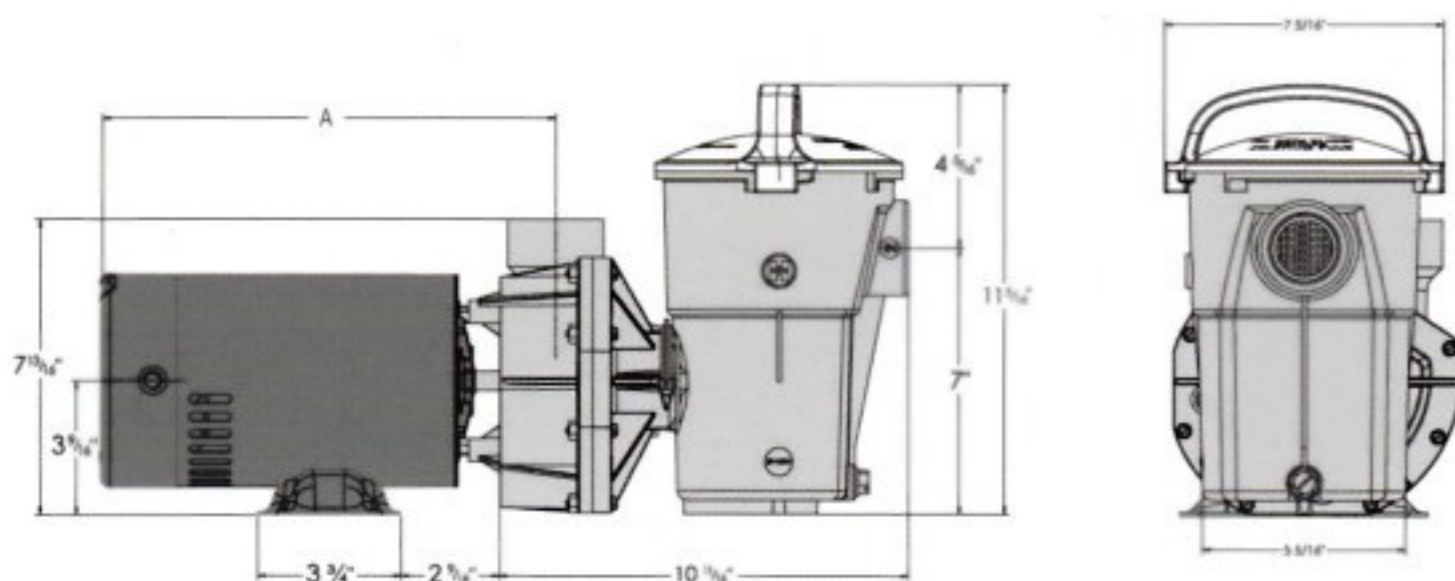

To take a closer look at Hayward Pumps, go to www.haywardpool.com



International Marketing Group
2875 Pomona Blvd | Pomona, CA 91768 USA