



E-Power High Performance Pump "EPH" Series

"EPH" series heavy duty pump delivers high flow and energy efficiency ultra performance. It is suitable for commercial swimming pool. 2 inch suction and discharge port with transparent lid. Ring lock seal design to eliminate suction leaks and to maximize suction efficiency.

- ### Highlight Features:
- Asynchronous, Two poles
 - Class insulation: 130
 - IPX5 Waterproof standard
 - Built-in thermal protection
 - Overload protection
 - Available in 50Hz or 60Hz with 220V/380V/110V
 - Special design union compatible for both Imperial and Metric measurement standard
 - S.S 316 shaft
 - S.S 316 Mechanical seal

Technical Information

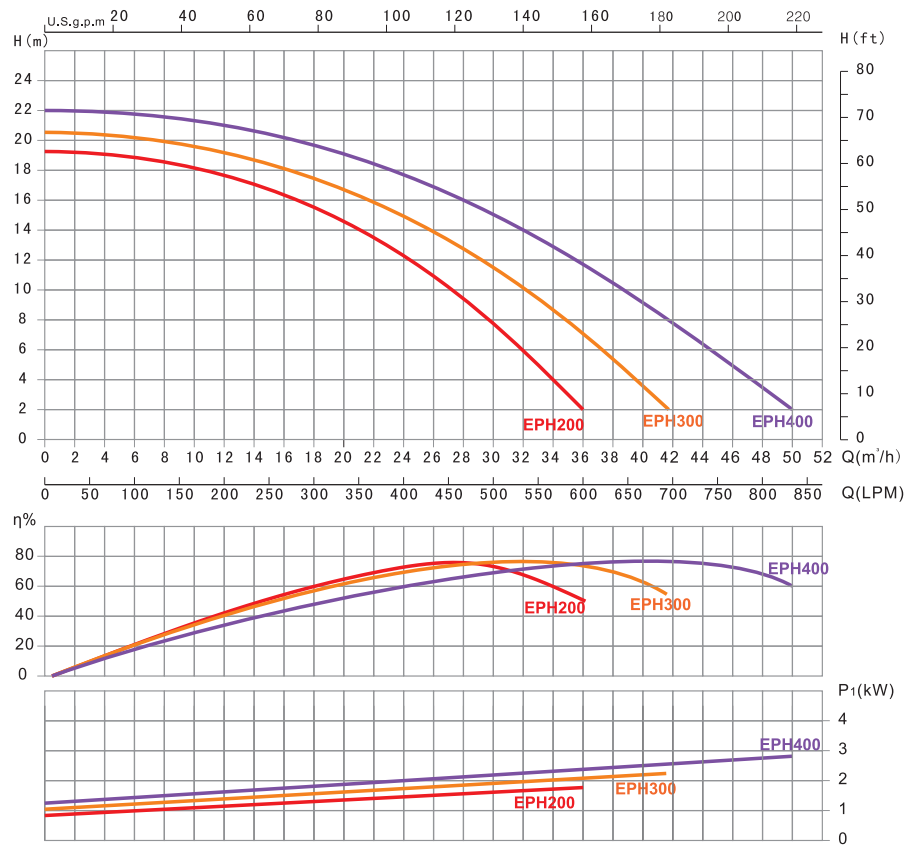

Remarks: Flow curve information based on 220V/50Hz motor.

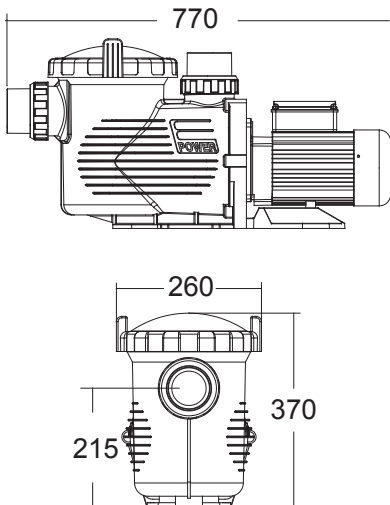

Product Information & Dimension

Code 220V/50Hz	Code 220V/60Hz	Code 110V/60Hz	Code 380V/50Hz	Model No	Connection Size	Input power	Horsepower	Weight(kg)
88020708	88021008	88020908	88020808	EPH200	2.0 inch 2.5 inch	1.80kW	2.0hp	23.00
88020709	88021009	88020909	88020809	EPH300	2.0 inch 2.5 inch	2.20kW	3.0hp	24.00
88020718	88021018	-	88020818	EPH400	2.0 inch 2.5 inch	2.80kW	4.0hp	25.00

