

# "SB" Series Extreme Centrifugal Pumps



EMAUX "SB" Series Extreme Centrifugal Pump is engineered to deliver ultra performance to both high and medium head installations in large-sized swimming pool and commercial spas. This high flow pump is design to exceed to exceed builder, service professional and customer requirements.

**Standard features include:**

- \* Corrosion protected shell to prevent water directly contacting with motor.
- \* Easily assemble pump basket.
- \* Pump basket size to allow twice normal dirt load before cleaning.
- \* High performance to ensure maximum turnover rate of water.
- \* Improved suction characteristics to ensure maximum efficiency form automatic sweeper.
- \* Exclusive double ring-lock design give "tool free" access to strainer basket.
- \* Lid designed to eliminate suction leaks and to allow positive checking of lid seal under load.
- \* Design for easy maintenance and repairs.
- \* Through test repeatedly, guarantee real output power.



"SB" Series Extreme Centrifugal Pump

- \* Low cost of spare parts.
- \* IP55 Waterproof Standard.
- \* CE Europe Standard
- \* Five-Year Limited Pump Housing Warranty.

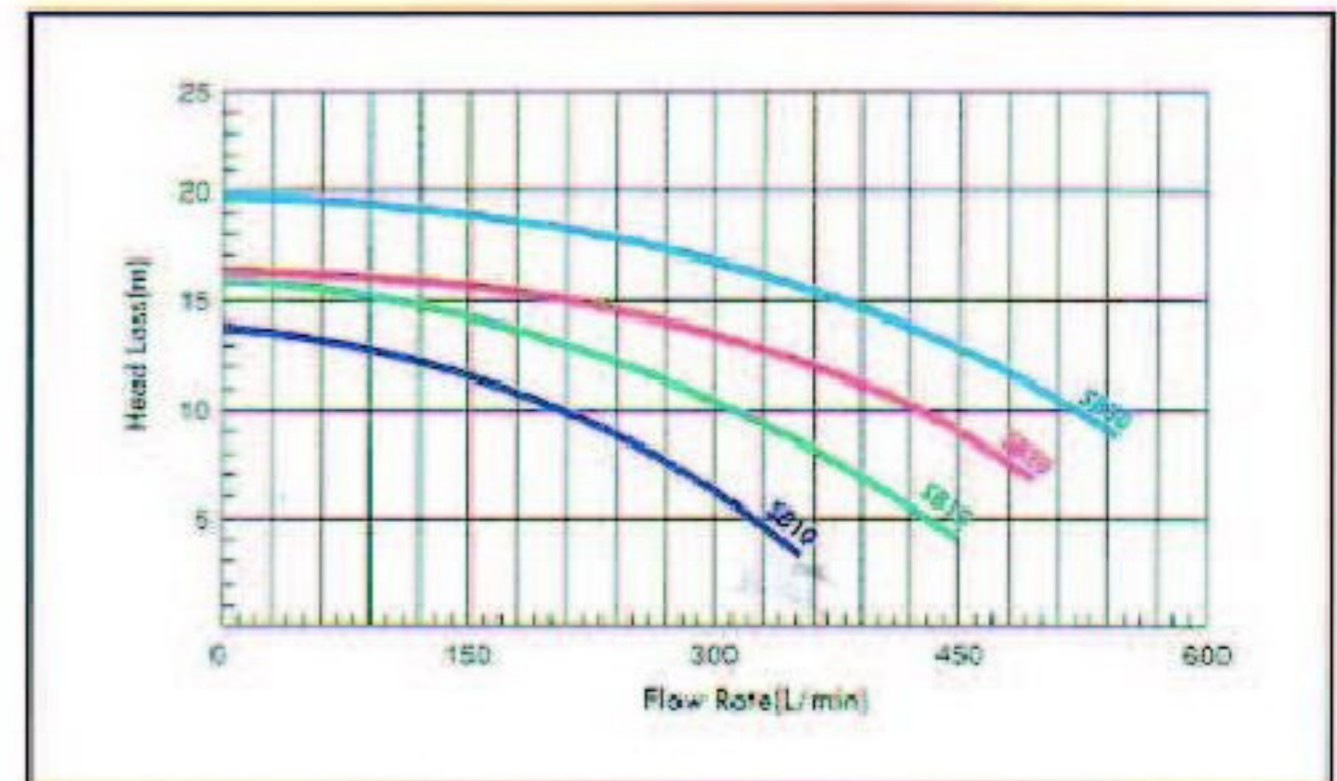
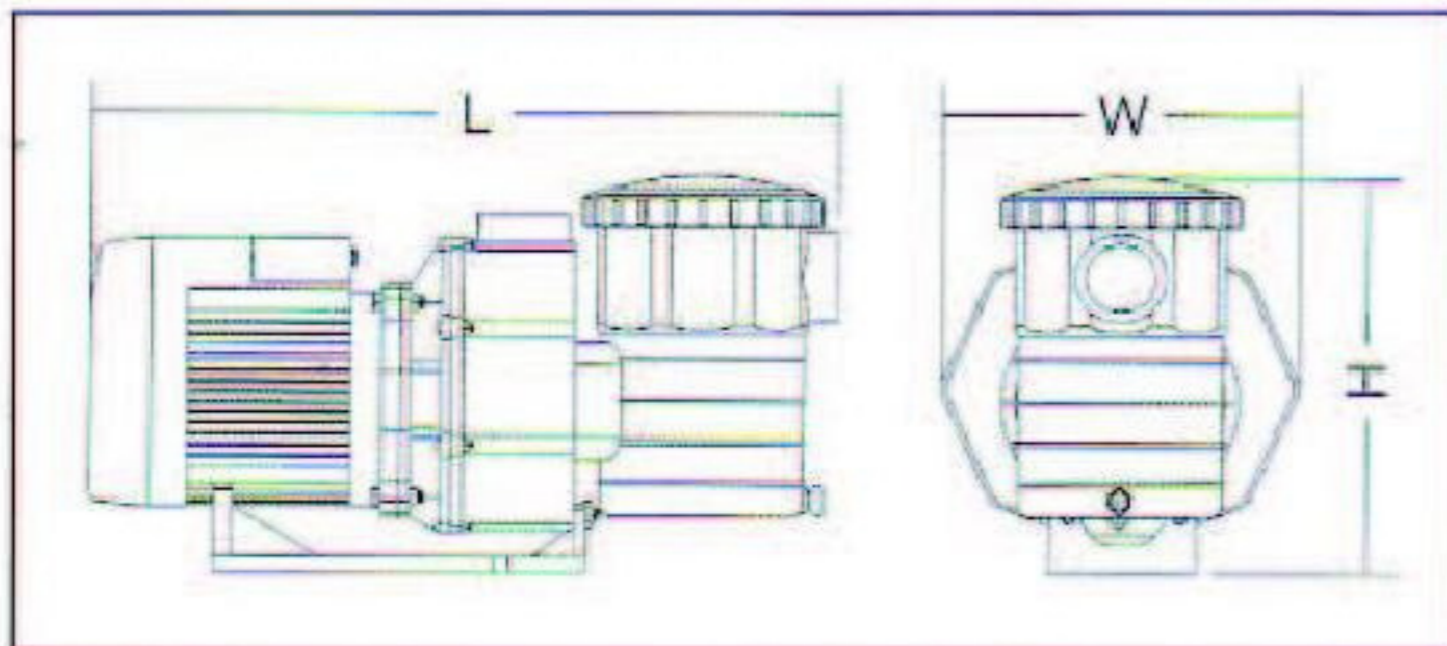

## TECHNICAL CHARACTERISTICS

Model No.	Power (kW)	HP	Length (mm)	Width (mm)	Height (mm)	WeightPort (kg)	Size (inch/mm)	Voltage (v)	Phase
SB10	0.75	1	600	280	350	16	2/50	220/380	1 / 3 Phase
SB15	1.10	1.5	600	280	350	17	2/50	220/380	1 / 3 Phase
SB20	1.50	2	610	280	350	23	2/50	220/380	1 / 3 Phase
SB30	2.20	3	610	280	350	24	2/50	220/380	1 / 3 Phase

Your Dealer:

WE RESERVE THE RIGHT TO CHANGE ALL OR PART THE FEATURES OF THE ATTACHED OR CONTENTS OF THIS DOCUMENT WITHOUT PRIOR NOTICE